



AUTODESK[®] AUTOCAD[®] PLANT 3D

AutoCAD Plant 3D – How to Manage Large Projects

Large projects are not handled by a single designer and so correspondingly, a large project should not reside in a single DWG. Sounds logical, but how do you divide up a large project so that many designers can work together as a team. Split it up into lots of DWG's! Sounds easy, but how?

This document will give you some ideas as to how to organize your Plant 3D project so that the project remains as a single project for reporting and yet has many drawing / model files, so that designers of different disciplines can work together and yet work with manageable data sets so that modeling response remains good. The way we will do this is through extensive use of XREF's.

And just as no two projects are the same, there are many different ways to organize a project. We'll suggest one way, but you can modify these suggestions in order to suit your needs better.

Contents

- Getting Started..... 3
- Setting Up Your Project..... 3
 - Controlling Rights between Disciplines..... 4
- Working With Xref's..... 5
 - Simplifying Working with Xref's..... 6
 - Modeling Using Xref's 7
 - Managing Drawing Sizes With Xref's 8
- Data Management 8
 - Working In a Distributed Environment..... 9
- Managing Deliverables..... 9
 - Piping Isometrics..... 10
 - Orthographic Drawings 12
- Working with a Master Model 14
 - Working with Navisworks 15
 - SQL Server 18
 - Autodesk Vault..... 19
- Conclusions 19
- Appendix 1 – Managing Drawing Rights Access 20
 - Windows Folder Structure 20
 - Plant 3D Project Folder Structure 22

Getting Started

Before you start to create the project in Plant 3D, take a big step backwards and look at the project as a whole. Think about how to logically split it up. If it is a big site, all on one level mainly, like a refinery then look at a site plan and then divide it up into areas. Each area may be a process unit, or it may be a logical sub-division of a process unit, but consider it as an AREA. In the case of a multi-story plant, you may want to treat each floor as an area and then subdivide into physical areas.

In this example we will be working on a refinery-like project. We have a site plan and into that we have broken it up into a number of areas:

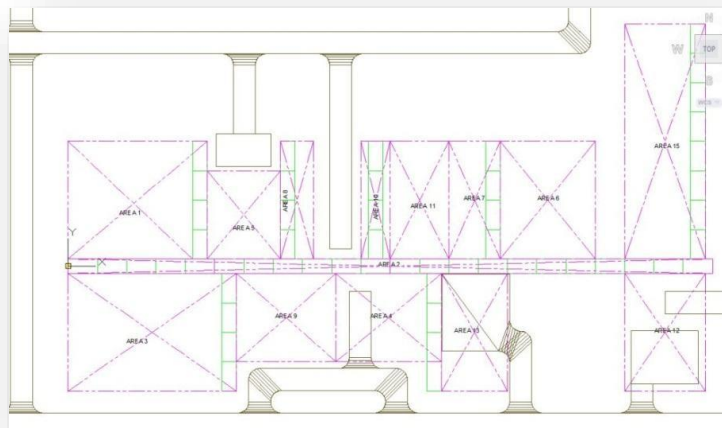

In this case we have 14 areas. In the middle is a pipe rack which joins up the separate areas (Area 2), this is considered a separate area since we want a designer to be responsible ONLY for considering the layout of the pipes in the rack. Area 13 is a servicing area and contains no 'plant' items (i.e. the models in this area are AEC models, not Plant 3D models) and so there are no P&IDs and no Plant models in this area.

Within each area we have to consider Equipment, Structures and Piping. And if we have different designers focusing on each discipline, we probably want to divide up our areas into the disciplines.

Setting Up Your Project

Using the example above we have decided that we will have 14 areas. Each Area can managed by a lead designer but each area has a design team comprising equipment layout designers, Structural layout designers and piping designers.

In the case of P&ID's we have split the project up into 3 process areas plus one utilities area which will contain all the Utility P&ID's (or ULD's). The fact that the P&ID Area will span several of the Piping areas is not important as Plant 3D will track and manage all the lines and equipment in the project.

So the project will look like this in Plant 3D Project Manager:

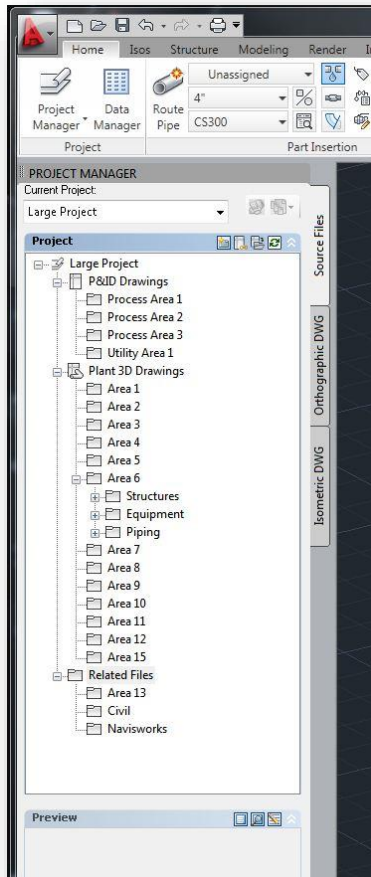

Note we have 4 P&ID Area's and 13 Piping Areas. We have also allocated folders in 'Related Files'. Here we will store or reference the site plan drawings in the 'Civil' folder. Since Area 13 does not contain any Plant 3D models (it is AEC) we have placed Area 13 in the section of the project. We also created a Navisworks folder so that we can store the associated .nwf files which will allow us to assign materials to the model files in order to create realistic renderings of the model while we are designing. We can also place the .nwd files here for project review sessions. This allows project reviews to take place while design work proceeds, without interrupting design work

Now looking at Area 6 as an example:

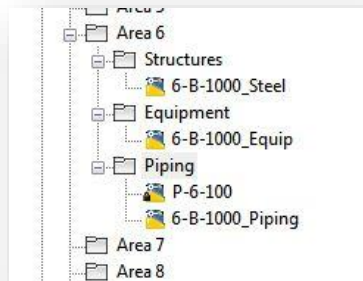

We have created a Structural file in the Structures folder, an Equipment Modeling file in the Equipment folder and 2 Piping files in the Piping folder.

This structure keeps the file content small and manageable and yet allows maximum flexibility in working in the project. By using Xref's, the designer can focus on the part of the model he is particularly interested in at any moment by unloading the Xref's he doesn't need. Then when he needs more information, simply reload the Xref's for full model realization.

Controlling Rights between Disciplines

In some organizations CAD Managers feel more comfortable controlling who has write-access to drawings based on their discipline. For example, so that Structural designers cannot change piping configurations. Many CAD Managers (or Project Administrators) do this by setting access rights at the folder level. In the above example, the hierarchy is area-based and disciplines are sub-folders of the area. In this case, the administrator will need to set rights for every discipline in every area. Note that this would be done at the project setup and the rights would only need to be changed when project personnel change.

You set access rights directly to files and folders in Windows explorer. AutoCAD Plant 3D recognizes access rights, but you do not manage access rights in project setup.

An alternative approach could be to set a folder structure with the disciplines at the top and areas are sub-folders for each area. In this approach the rights need only be set at the discipline folder level. The project would look something like this:

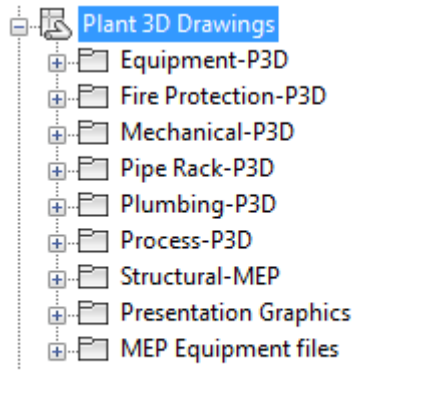

However, Plant 3D folders do not need to exactly match the windows folder structure, so it is possible to set up the project folder to be hierarchical based on areas (as shown above) but have the windows folder structure be set up based on disciplines. See Appendix 1 for more information on how to set this up.

Working With Xref's.

Plant 3D is designed to work *intelligently* with Xref's. Pipes and Piping Components will connect to pipes and piping components, and even equipment nozzles, in Xref models. So when using the Route Pipe command, by clicking on the equipment nozzle in the Xref, the connection will be made and the correct components will be placed as shown here:

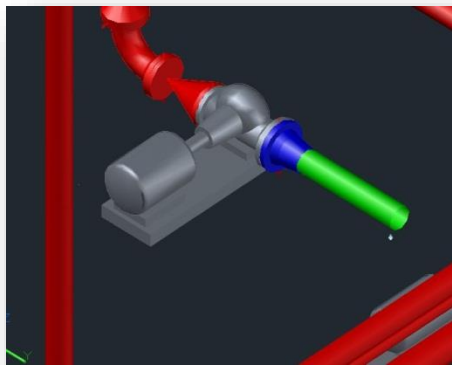

Note that the pump is in the equipment Xref and that since we were routing an 8" line and connecting to a 10" nozzle, a 10" mating flange with a 10x8 reducer was placed in the piping model. Also note the connection adds bolts and the gasket..

Simplifying Working with Xref's

One useful way of managing the Area Xref's is to have a master area drawing. This is essentially an **empty** model file with **all** the area models loaded as Xref's. In this example Area 6 master area drawing is Area6.dwg:

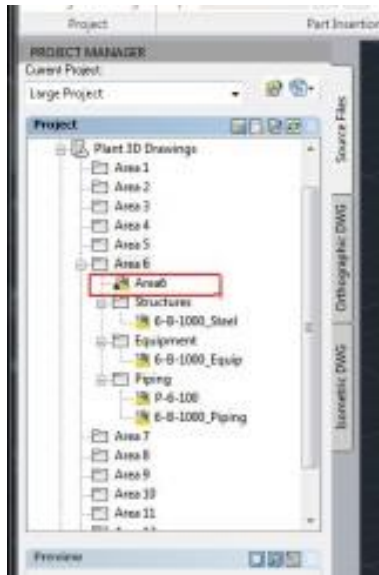

It is important that these Xref's be loaded as **Attachment** and it is recommend that you use relative path as shown below. Setting the Path Type to Relative Path makes moving the project easier.

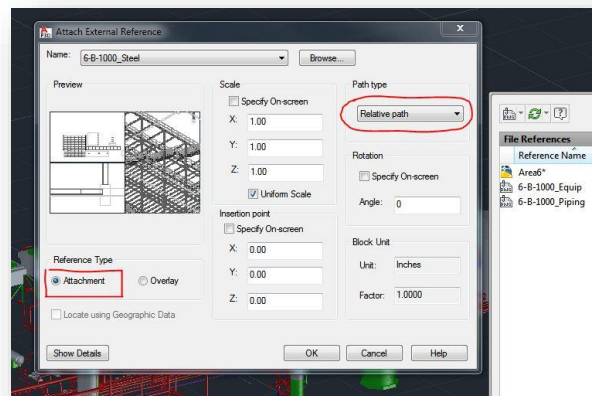

The Area Master file is maintained by a project lead who ensures that **all** the model files in that area are attached. The reason we will use **attachment** reference type, rather than the usual overlay, is that we will be using these Area Master files as Xref's in the Master Model (see later) and we want the nested Xref's to display.

By creating these Area Master models, we make managing model files in the area simpler. Now any designer working in that area simply attaches this one file as an Xref, **but in this case in Overlay mode** and he will be sure that all the models in that area are attached. (A warning message detecting circular references may be displayed, simply click on Continue.) If working across areas, for example connecting pipes to a pipe rack that may be in a separate area (for example attaching to pipes in Pipe Racks), then simply attach that Area Master drawing and then detach (or unload) when no longer needed.

Word of warning re Circular References: If you follow the guidelines above, then circular references (file referring back to itself as a lower nested Xref file) will be taken care of by AutoCAD. The danger arises when you need to Xref a file in another area. In this case if you attach the **external area** file to your model file as an **attachment**, you will create circular references in the Master Model file (see below) or in the Orthographic Drawing master model files. To avoid this problem, best practice is to use the **overlay** reference type for these external files.

Designers can turn on / off any layers in the reference files or unload the whole reference file as needed.

Modeling Using Xref's

Xref's make it very easy to work in large models. Here the piping designer is concentrating on piping around a pump:



By unloading the structure and turning off some of the piping layers, a better view is obtained making piping easier:

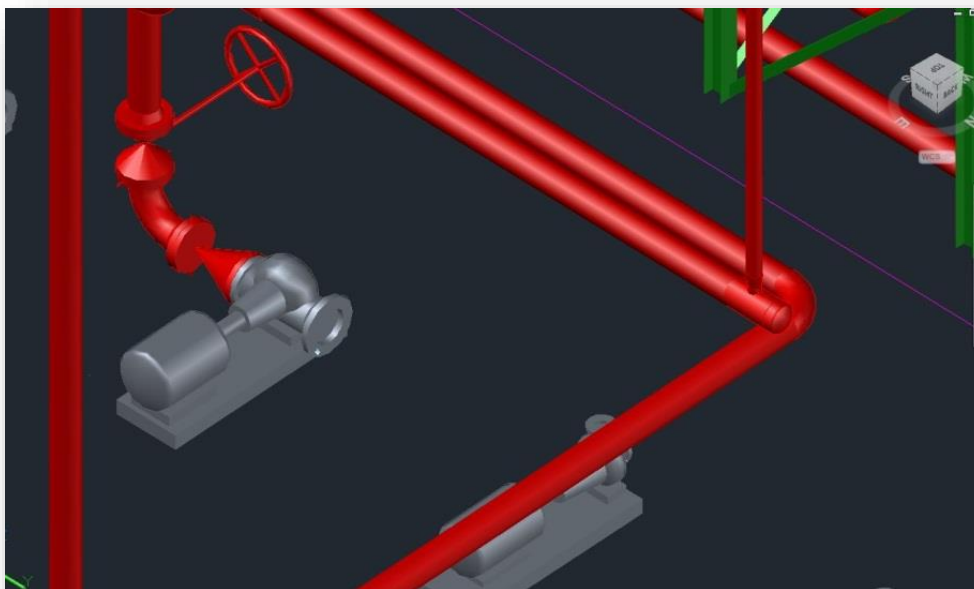

Managing Drawing Sizes With Xref's

The optimum size for a model file is 5-10mB. Depending on the hardware you are using and the type of plant model it may be better to keep the model size smaller. This can be especially true if you have objects that are not Plant 3D objects (e.g imported from Inventor or Revit). This will result in more dwg files, but good model management will maintain good performance. It doesn't matter how many files you have in the project, AutoCAD Plant 3D project manager can manage large numbers of drawings.

With experience, you'll be able to guesstimate how many lines or how many equipment items will be in each model file in order to keep the sizes down, but there is no problem adding more model files as the project develops. This is especially true for piping files.

Some users like to put all equipment in an area into one dwg. Others like to split them up into sub-areas where others may split the equipment up by levels on a structure.

In the case of structures, many users will place a 'single' structure into a single model file. This is so the structure can be exported for analysis and then replaced with a detailed structural model after the detailed engineering has been done. In some cases, the structure may actually extend across an area boundary. This is not a problem, simply place the structural model in **one** area and then have the master area model of the other area(s) Xref this structural model.

Pipe Racks are typically handled separately too. This is to allow the piping designer to optimize the space available on the rack and this is its own layout problem. Thus the Pipe Rack area may also contain sub-racks which will encroach into process areas. The best practices approach discussed so far handles this approach easily.

Managing piping models can be done in many different ways. Since Plant3D allows intelligent connections across Xrefs. Thus piping models can be divided into sub-areas or by line numbers, with each designer allocated a certain number of lines. There are no constraints on how to divide up the area.

Data Management

AutoCAD Plant 3D uses an SQL database in order to manage non-graphic data. The default SQL database engine delivered with Plant 3D is **SQLite** (www.sqlite.org) Everything you need to manage the data within a Plant3D project is delivered with Plant 3D and you do not need to be a database expert nor do you need to understand SQL databases in order to use SQLite. SQLite is a simple and effective solution for managing data in smaller projects where integration with enterprise databases is neither necessary nor desirable. Thus small companies can use SQLite for their projects and Plant 3D Data Manager will be an effective interface to the project and drawing data. For more information on SQLite visit <http://www.sqlite.org/about.html>

For larger organizations who have large amounts of data stored within Enterprise Databases, Plant 3D supports SQL Server. The inclusion of SQL Express in Plant 3D allows you to select whether to use SQLite

or connect to your corporate database. A tool is included with Plant 3D that will convert your project from SQLite to SQL Server.

When should I stick with SQLite and when should I use SQL Server? This is a difficult question to answer and it depends more on how you use the data rather than how many users need to access the project database and the performance of your file server. If you are already using corporate databases and want to share the Plant 3D data with other database applications, then SQL Server is definitively the correct answer. If your project users are distributed geographically, then SQL Server may be the best solution as the database server will manage the distribution of the database, or manage the centralization of the data.

Regardless of whether you use SQLite or SQL Server, the Data Manager allows you to extract data to Excel spreadsheets for non-CAD users to manipulate the data.

Working In a Distributed Environment

Buzzsaw (www.buzzsaw.com) offers a very useful way of placing files in a central server to allow distributed users to access these files if you do not have a central server and WAN for project collaboration, or if you have external people/companies working on a project and you do not want to grant them access to your local network.

Autodesk® Buzzsaw® software as a service (SaaS) delivers document, data, and design management solutions to architecture, engineering, and construction (AEC) firms and owner-operators. Autodesk Buzzsaw helps organizations centralize and more securely exchange project information inside and outside their organization. And with proven SaaS technology, your company can focus more on project delivery and less on managing costly IT infrastructure.

Buzzsaw comes with a Buzzsaw Sync utility which allows you to sync local folders with those on Buzzsaw. Although Buzzsaw Sync allows you to have continual syncing, you may find it more manageable to only perform syncing at certain times of the day. (This avoids continual messages to reload Xrefs.)

The inclusion of Autodesk Vault support within Plant 3D also allows you a clean way to support projects across multiple offices and ensure data consistency.

Managing Deliverables

The most common deliverables that are generated are Piping Isometrics and Piping Orthographic drawings. Generally, Isometrics are generated per line number and orthographics (ortho's) are generated per area, with additional drawings being generated for sections and elevations. They are managed differently

Piping Isometrics

AutoCAD Plant 3D Project Manager manages all the isometric drawings for you. It has separate folders for all the iso styles you need to create and setting up the styles and the locations for these drawings is managed through Project Manager > Properties:

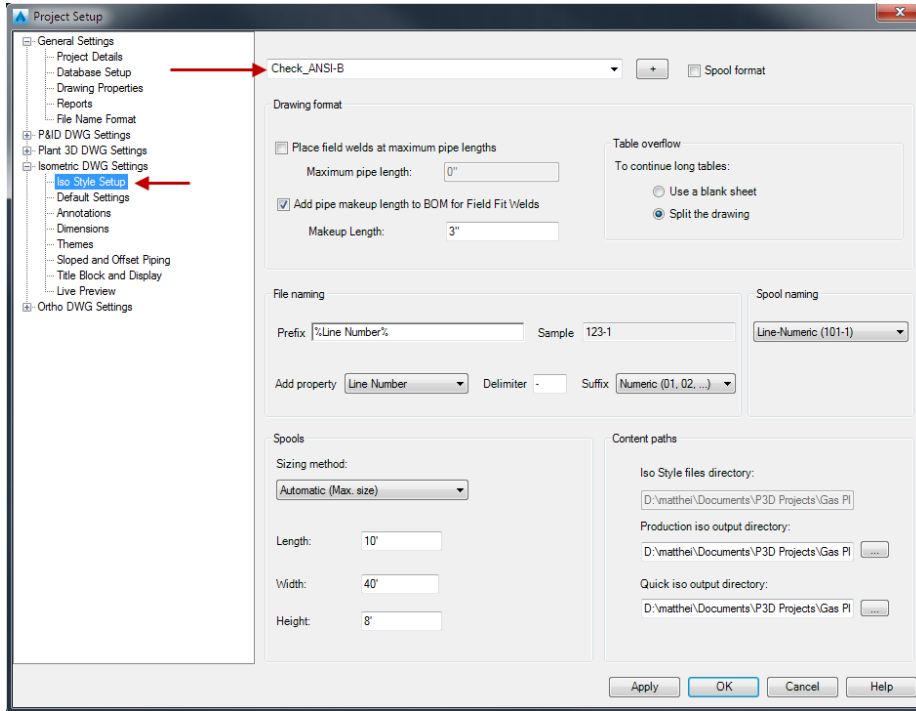

Isometrics are created by line number and are sorted by Iso style in the Project Manager:

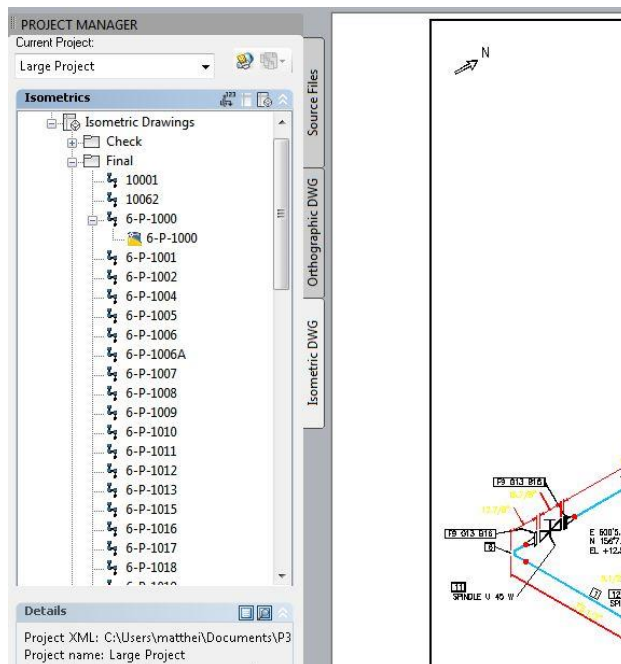

Isometrics can be created just from a drawing, in which case only those piping components in that drawing will be extracted to the iso, or for the whole project. In this case the whole line (across several model files perhaps) will be extracted into the single isometric. Note that an isometric drawing may be split into several sheets. Each sheet will be a separate dwg.

Because the isometric is extracted from the 3D model, most CAD Managers do not allow isometrics to be edited in any way. This prevents inconsistencies between the model and the isometric.

Orthographic Drawings

Orthographic drawings are created from a selection of files that are available in the plant 3D drawings under Source Files. The files are selected in the ortho creation process and may be selected to create Area plans or master plans. Sections and details include fewer files since they are showing smaller areas of the overall project.

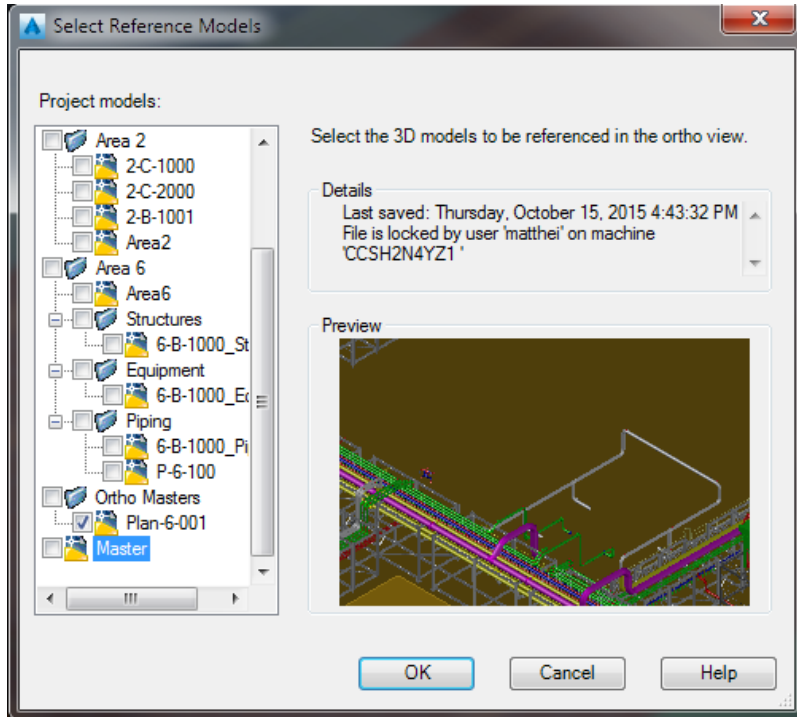

Layering for the generated view is controlled by Ortho DWG Settings.

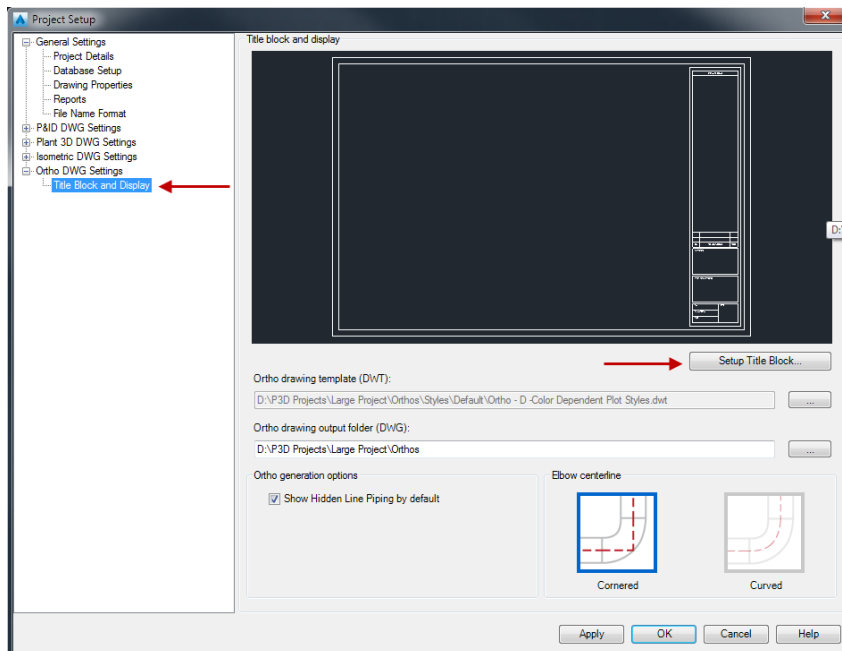

Layers can be used from the 3D models or objects can be placed according to specified layer settings.

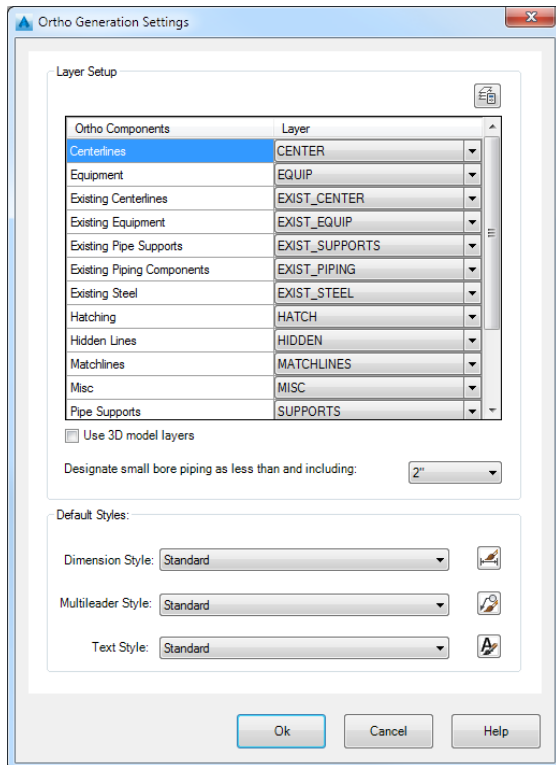

To update the orthographic drawings, the model must be changed first. Then the user can open the ortho, select a viewport and use the Update View command.

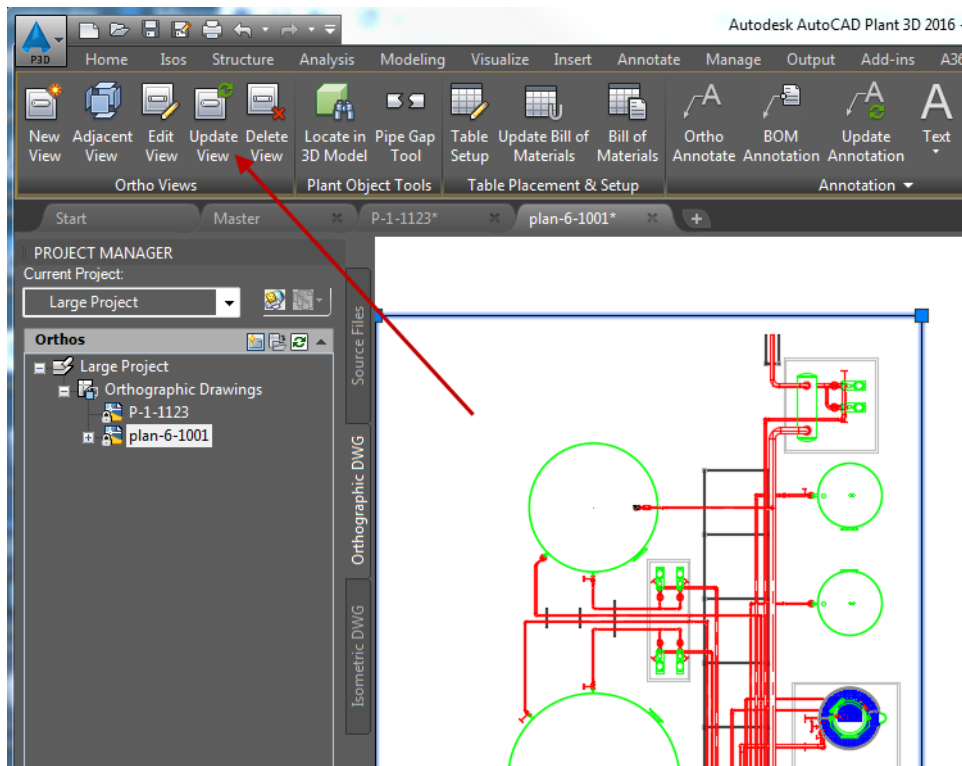

The above process may look like we will have many files to manage, and this may be true. But by managing them in this way, drawings can be created at any time, even while modeling is going on and then drawings can be updated consistently.

Working with a Master Model

Project Managers often want to check on progress. By maintaining a Project Master Model (similar to the Area Master model) this process can be simple and will become the basis for project reviews. The Master Model is created by creating a model file that Xref's ALL the Area Master model files. (by following the rules stated earlier as to when to attach Xref's and when to overlay Xref's, circular references can be avoided. Here is an example:

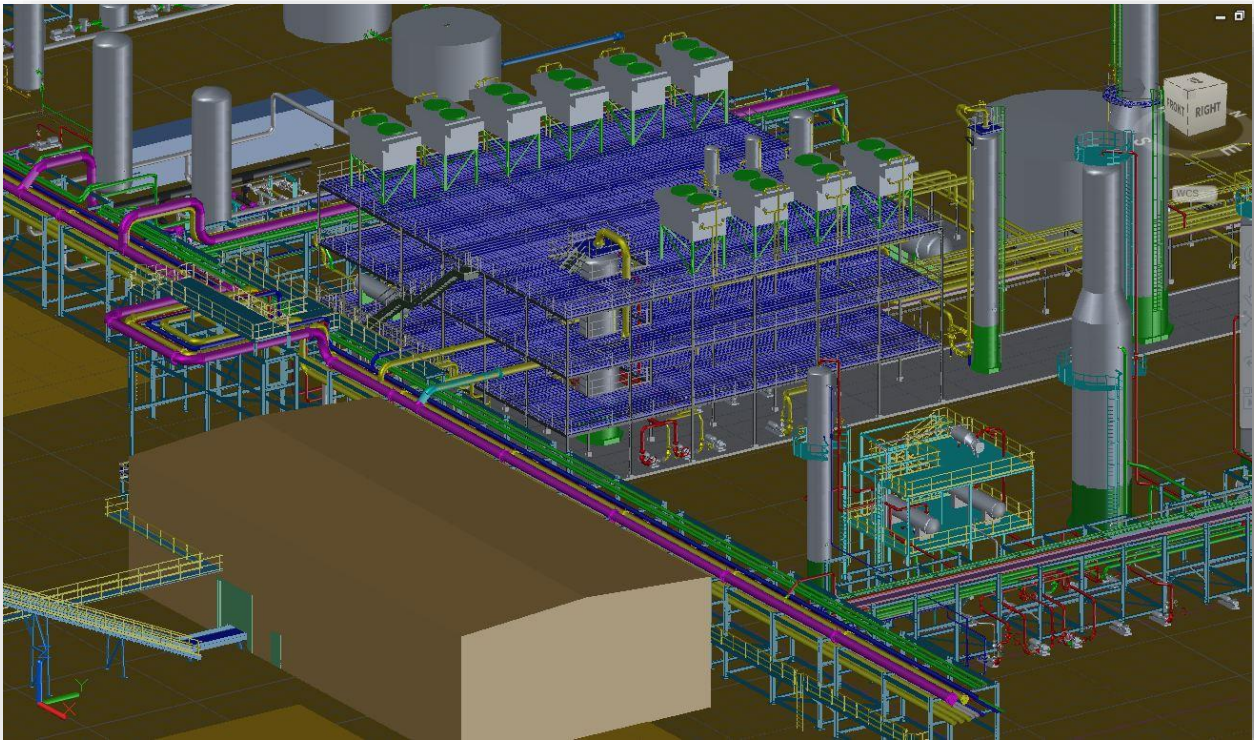

By simply reloading the Xref's at certain times in the project you will have a project Review model which can be exported to Navisworks. Depending on the size of the project, master files may become too large for AutoCAD to open. In these cases, a master nwf (.nwf) should be created that merges all of the area models together.

Working with Navisworks

Depending on whether you want to work at a project level or at an area level, the process is the same. Simply start with the Master Model or the Area Model.

The first time you set up for a Navisworks review, open the Master Model **DWG** file. Now after performing any operations you want to do, save the model as a **NWF**. In future reviews, open the NWF file and comments, materials are retained even after the DWG files which are referenced have been updated.

Sometimes you want to do reviews at a particular milestone and want to save the project for further reviews even though the project design is continuing. In these cases, open the Master Model or Area Master **DWG** in Navisworks, and then save as **NWD**. All the model entities are now saved in a single source model which can be viewed using Navisworks.

For better performance, make sure the nwc or nwd files get closed after they are read.

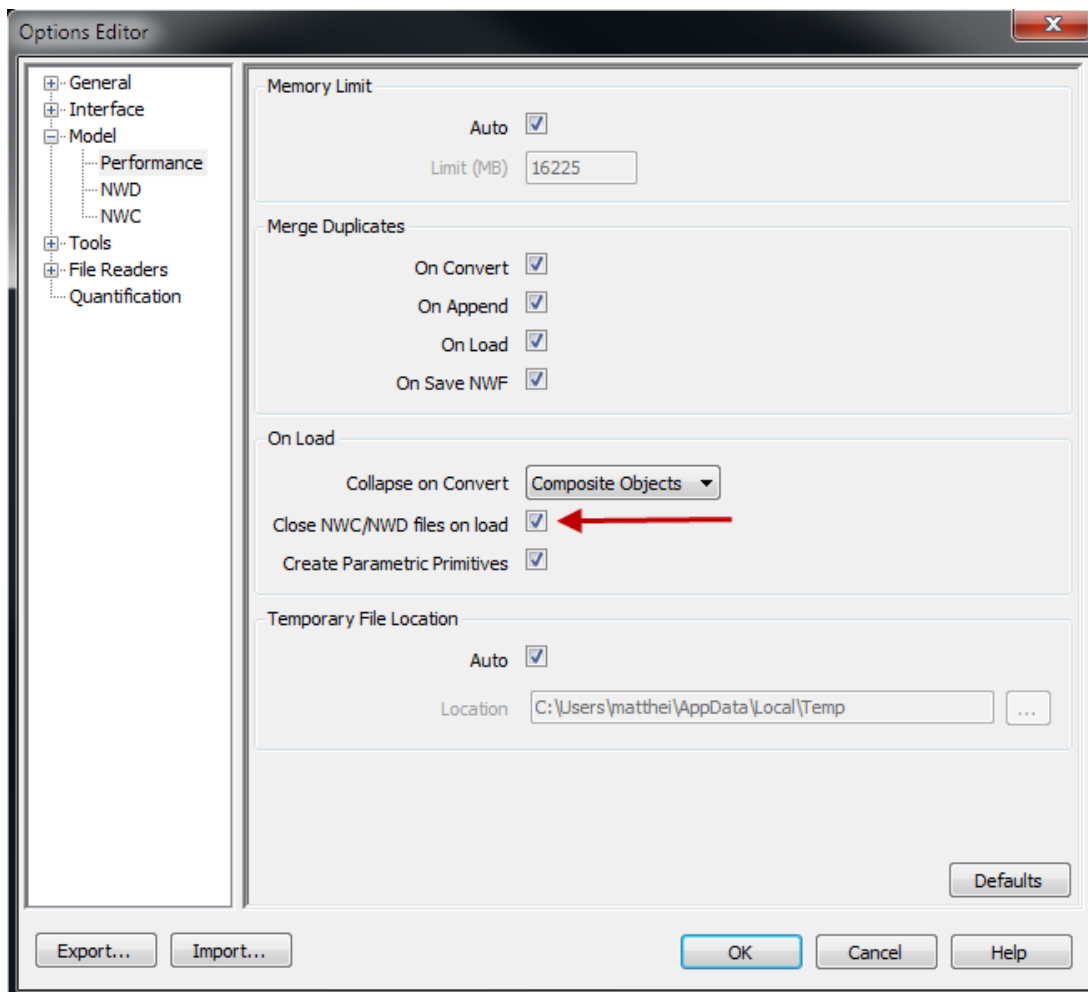

You should also enable occlusion culling, and toggle the Hardware Acceleration and WPF Hardware Acceleration if you are having performance issues.

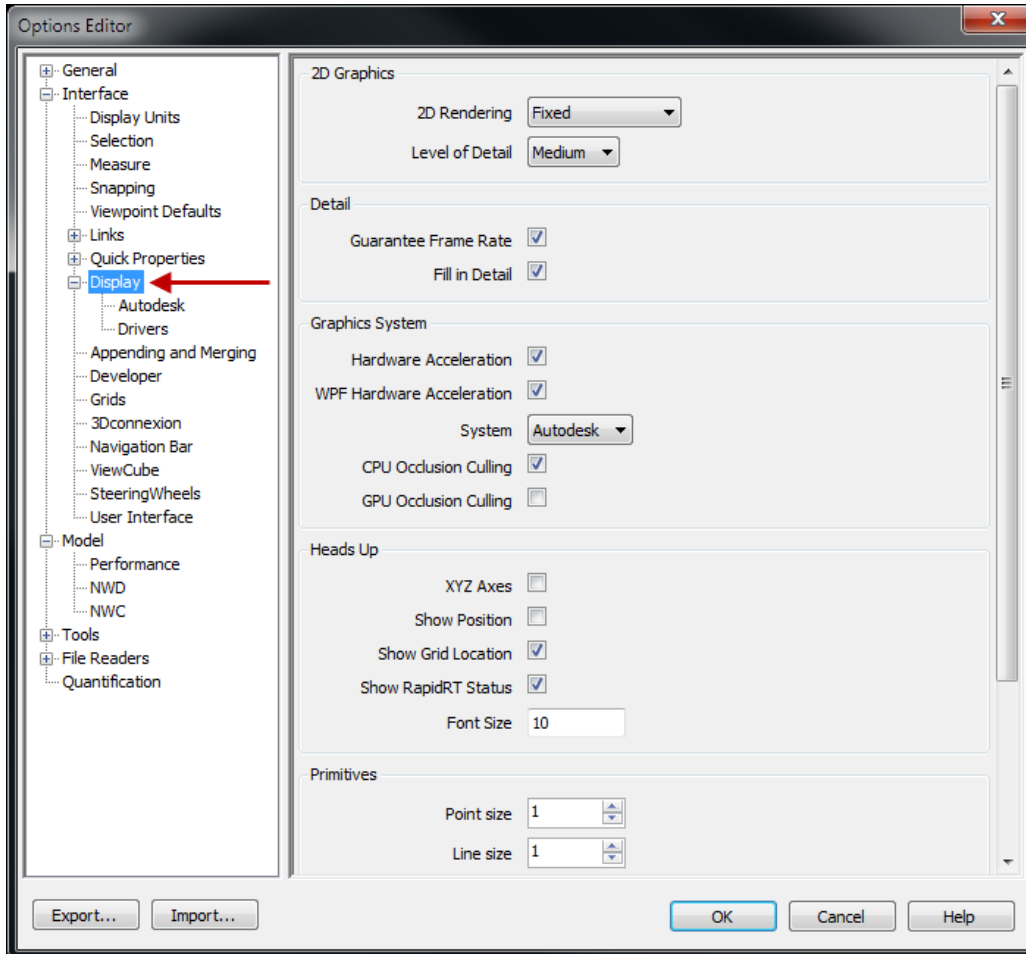

As a rule, only 3D model objects should be shown under render style. Enable other object types only if necessary. Limiting these enhances walking performance.

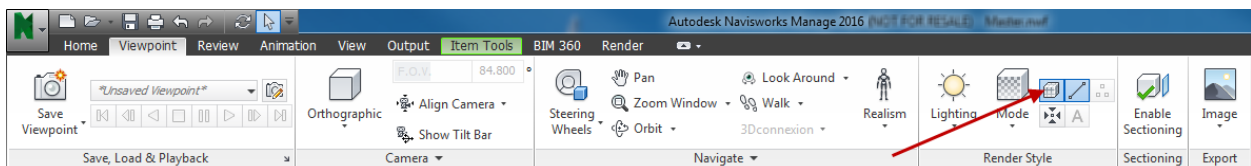

You may prevent Navisworks from even loading these objects at all under the following options:

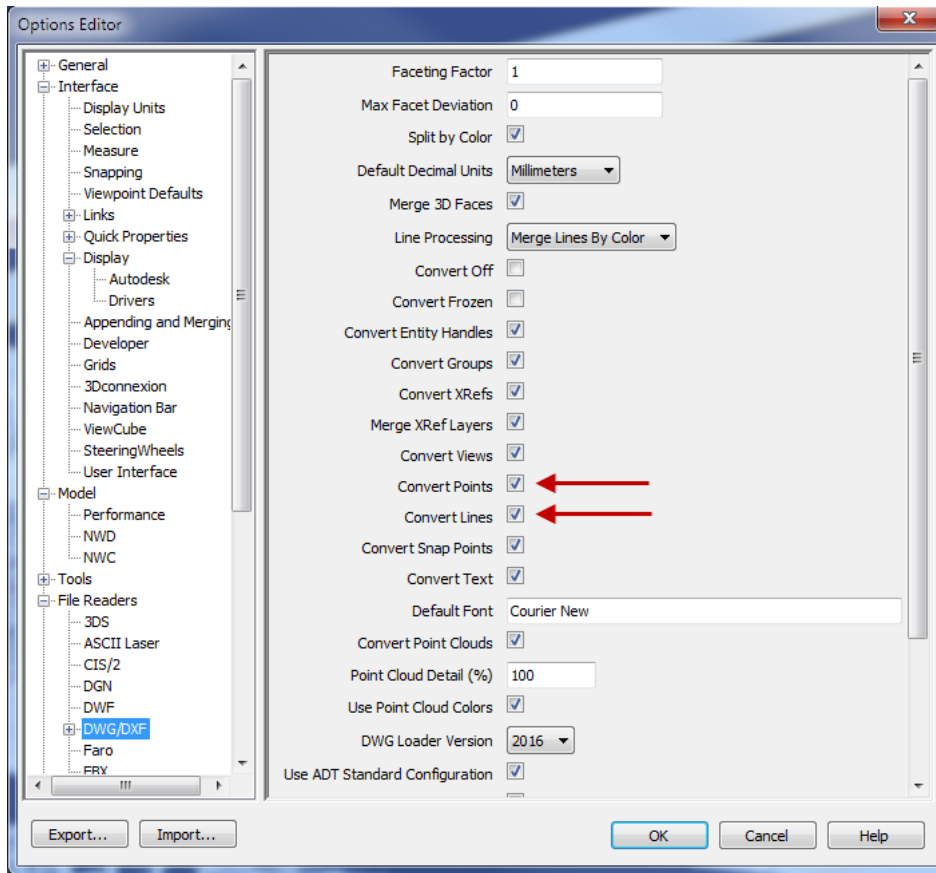

SQL Server

The decision to use SQL Server is driven by the number of users modifying the project data at one time. The default database type, SQLite, is valid for up to 2TB per file, so the project size is not the issue. Because the SQLite database is a single file, successful read/write depends on fast access. When more users access the database at one time, they have a higher chance of hitting the database at the same time (or close enough.)

Due to network configurations, server performance, computer performance, network loads and a host of other factors, a precise number of users cannot be given. However, according to SQLite.org, *“a good rule of thumb is to avoid using SQLite in situations where the same database will be accessed directly (without an intervening application server) and simultaneously from many computers over a network.”*

As a general suggestion (but not a rule):

- 1 – 2 active users in the project – use SQLite
- 3 or more active users – SQL Server

If you know you will have 3 or more active users, you should implement SQL Server Express or SQL Server.

You must also use SQL Server if you plan to use plant 3D with Vault.

Database Types

SQL Server – An enterprise-level product offering from Microsoft that includes a database server with administration tools for replicating databases between sites and other advanced features

SQL Server Express – A free product offering from Microsoft that includes a database server without advanced administration tools. You can still configure backups.

SQLite – An open source file-based database used by developers worldwide. The database engine is fast with good performance.

Articles on setting up SQL Server Express and creating backups are available here:

<http://www.pdoteam.com/series/plant3d-on-sql-express/>

Autodesk Vault

Autodesk Vault (<http://www.autodesk.com/products/autodesk-vault-family/features>) is document management software that integrates with many products in the Autodesk portfolio. In AutoCAD Plant 3D 2014, Vault became integrated into the Plant Project Manager.

Vault should be used in the following conditions:

- You have multiple sites that need to share data
- Your Plant project structure contains all external references.
- You can use SQL Server or SQL Server Express.

Vault allows you to store the drawing data in a central location, and have satellite offices check in/out drawings on an as-needed basis. Currently, all xrefs must reside within the project structure, as AutoCAD Plant 3D uses its own working directory for Vault projects.

Conclusions

This document is a guide to help you set up and manage a large project. It is a guide, not a bible, so feel free to adjust the recommendations to suit the way you work. And remember, designers need to have exclusive access to a model file while they work. So you need to have at least as many model files as you have designers!

Appendix 1 – Managing Drawing Rights Access

In this appendix we will give an example to show how you can manage a large project where different disciplines will have read-only access to other discipline drawings. In order to manage this the Windows folder structure is different to the Plant 3D Project folder structure.

Windows Folder Structure

Since we want to give Structural Designers Write Access to their designs and read-only access to the Piping and Equipment Layout designs, then it makes sense to create a folder for the Structures and a different folder for Piping Designers. If we also want to manage files at an area level, then we will create area folders as well:

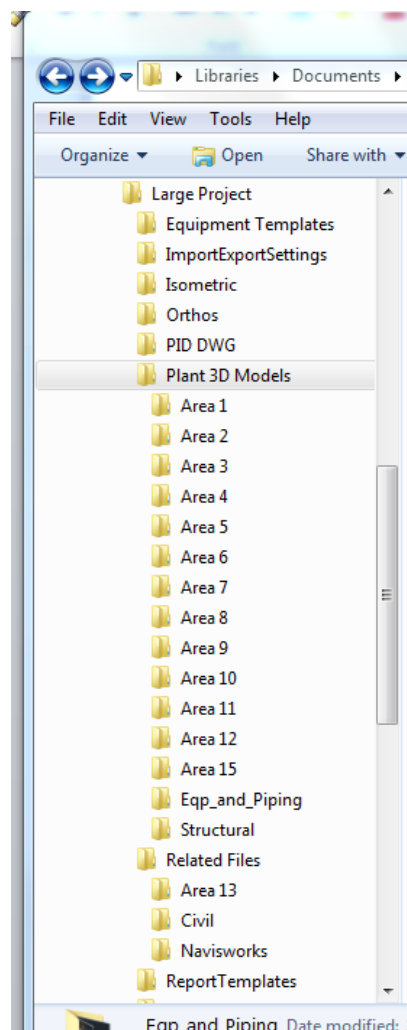

The folder organization could be extended to include area sub-folders within the discipline folders. However, a naming format which includes the area could be used so drawing files can be easily associated with the area.

Use the standard Windows Folder security features to assign rights to the folders:

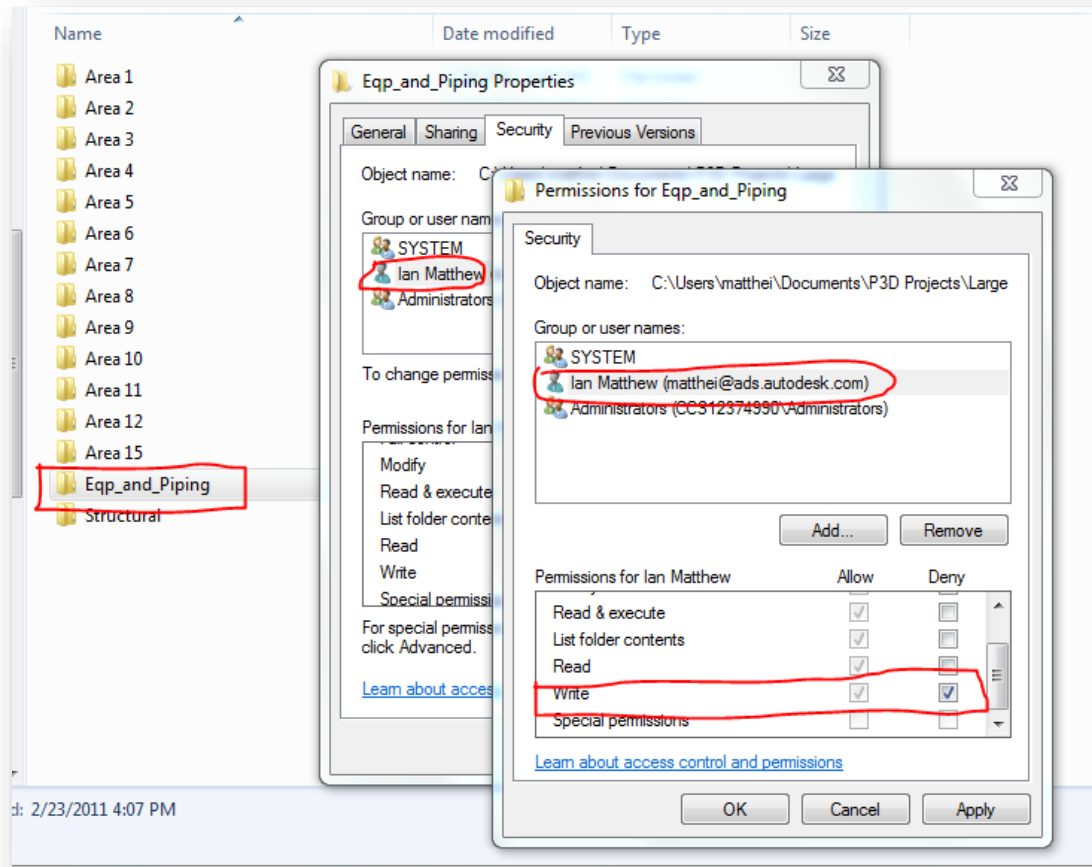

In the above example we have assumed the user is a structural designer so we are denying him write-access to the Equipment and Piping Folder. When this user opens a Piping or Equipment drawing, the following message will appear:

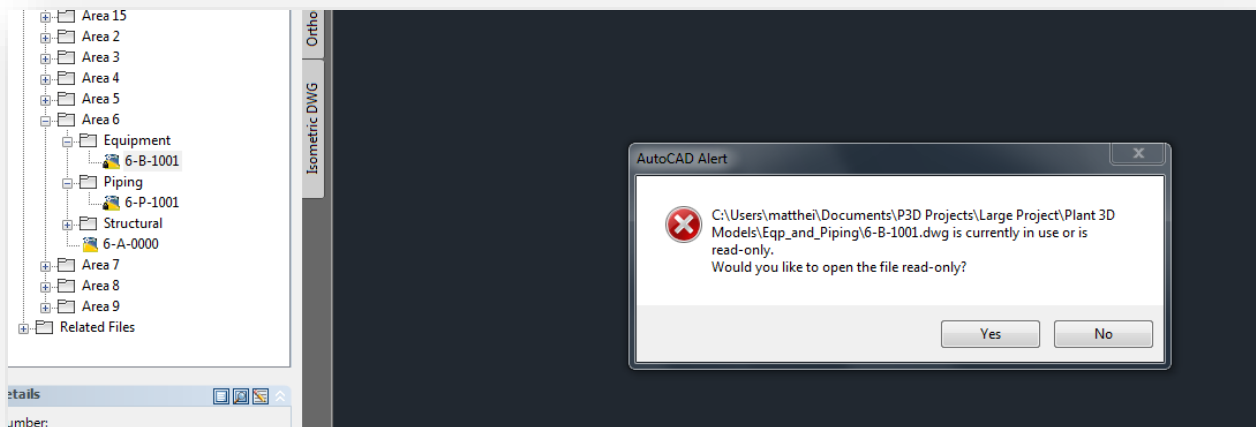

Plant 3D Project Folder Structure

In the project we want to create a structure by area and then by discipline as follows:

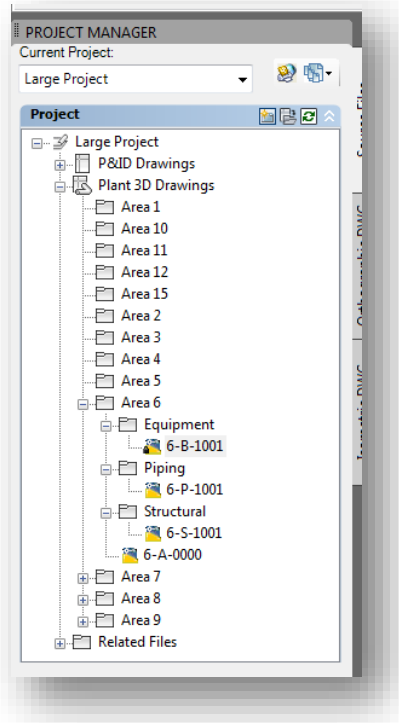

However, we want to ensure that the equipment and Piping drawings are stored in the project Equipment and Piping folder and that all the structural drawings are held in the structures folder (as we created in the previous section)

We do this by creating a new folder for the area and then linking this folder to the discipline folder we created previously:

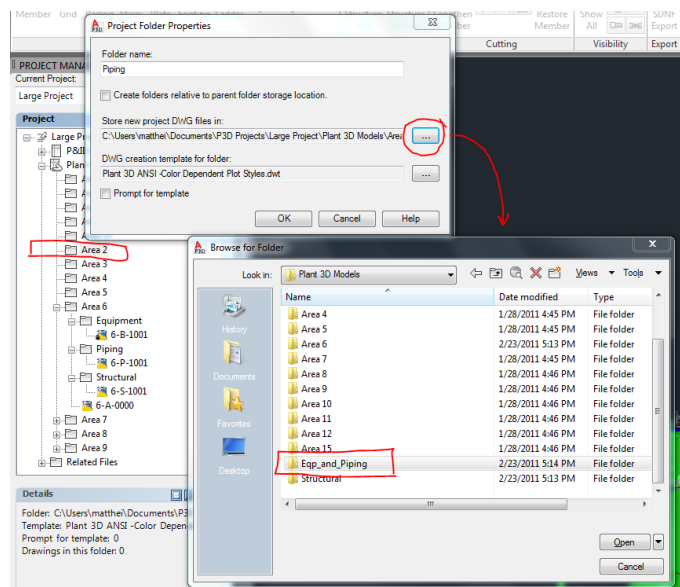

Now when we create a new piping drawing in an area (in this case Area 2) the Project Manager will show it as a member of the discipline folder in that area but the actual drawing file is held in the discipline folder and assumes the rights access of the folder:

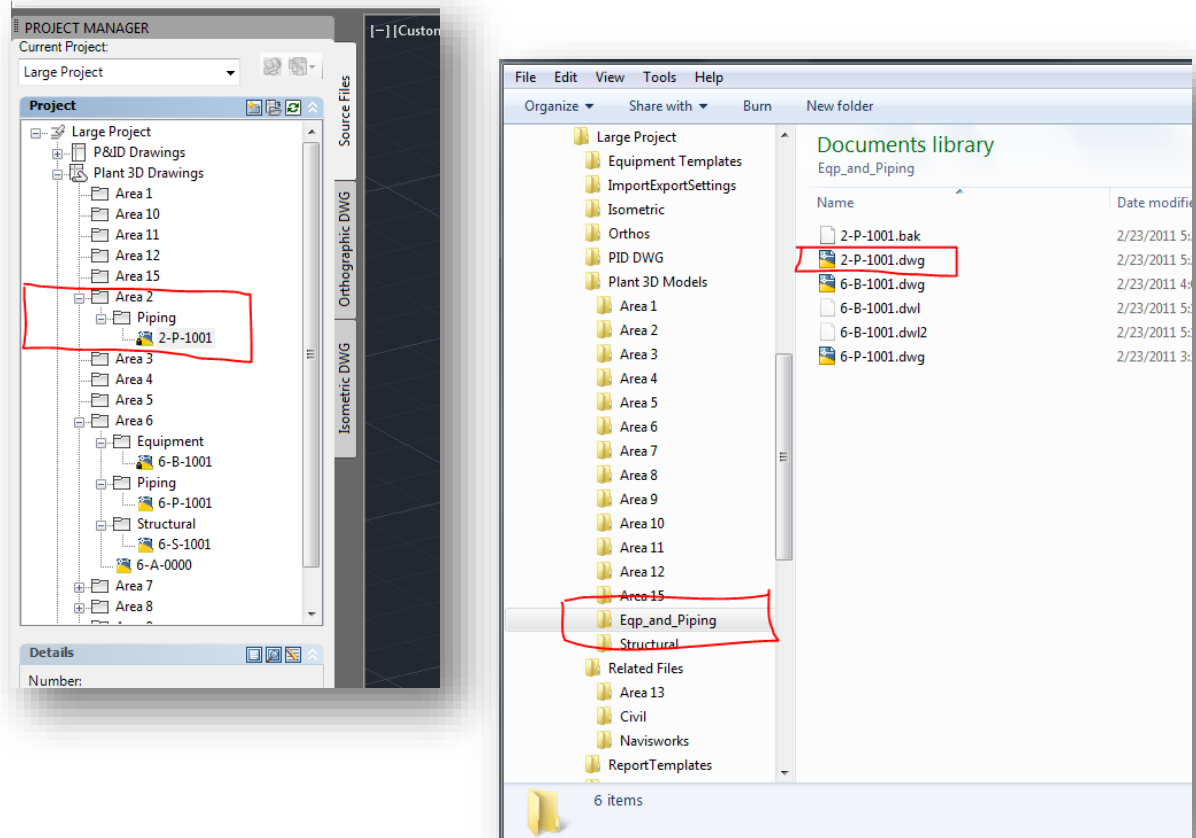

Although this seems a complex process it only has to be done at project setup time. Once the project is fully set up in Project Manager, the drawings will automatically be created in the correct folder.